

UPS-15NO~25NO

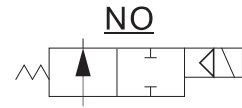
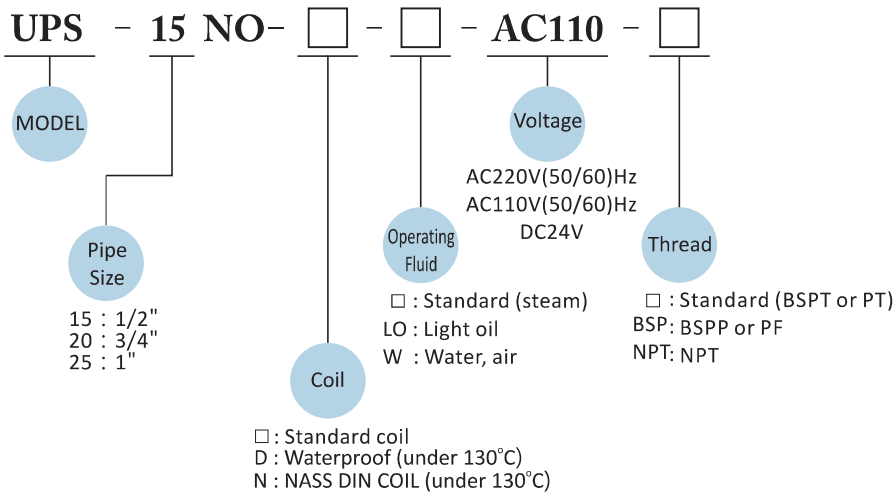

PRODUCT DESCRIPTION

- UPS-NO series is multiplex, piston guiding, conductive and normally closed (NC) 2/2 way solenoid valve.
- Recommend to apply to frequent operation
- Applied fluid type : water, air, steam, light oil
- Acceptable for customize Viton , Silicone and EPDM for seal plug and diaphragm

CAUTIONS:

- Minimum pressure to open: over 0.5kgf-cm²
- Before pipelining, the pipe line must be very clean without any contaminants or impurity.
- To extend the lifetime, Y-type filter at the front end of solenoid valve.
- AC voltage tolerance: ± 10%; DC voltage tolerance: ± 1%
- It should be installed horizontally; vertical installation is not advisable.

Not Suitable For Fluid As Below:

- Liquid status when it is in high temperature; solid status when it is in low temperature.
- Corrosive fluid
- Viscosity over 20 cst

MATERIAL:

PARTS	Coil	Tube	Spring	Core	Plug	Piston Spring	Piston	Piston plug	Valve body
MATERIAL	Special copper wire (H class)	Stainless steel	Stainless steel	Stainless steel	VITON	Stainless steel	Brass	PTFE	Forged Brass

SPECIFICATION

MODEL	Waterproof DIN/flying lead Coil	NASS DIN Coil (IP65)	PIPE SIZE	CV	ORIFICE	FLUID TEMP. (°C)	Operating Pressure kgf / cm ² (bar)					Dimension (mm)			Weight (kg)
							Water	Air	Steam	Light oil	Gas	L	H	D	
UPS-15 NO	●		1/2"	4.0	17mm	-5°C ~ +130°C	0.5~10	0.5~10	0.5~10	0.5~8		82	150	48	1.46
UPS-20 NO	●		3/4"	6.0	17mm	-5°C ~ +130°C	0.5~10	0.5~10	0.5~10	0.5~8		82	152	48	1.58
UPS-25 NO	●		1"	12	22mm	-5°C ~ +130°C	0.5~10	0.5~10	0.5~10	0.5~8		100	165	48	2.3

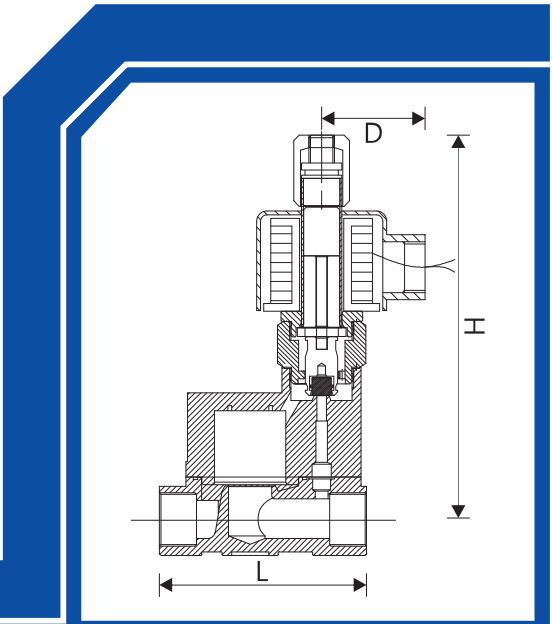

Normally Open Type